

Lithium-ion Battery

2 kWh - 12 V DC / 24 V DC / 48 V DC

Type M

A12020M

A24020M

A48020M

Type R

A12020R

A24020R

A48020R

Version 1.4

Operating Manual

English

Table of Contents

1.	Introduction	4
1.1.	General	4
1.2.	Terminology	5
1.3.	Explanation of Symbols.....	5
1.3.1.	Structure of the Safety Instructions	5
1.3.2.	Symbols, Warning Signs and Mandatory Signs	6
1.3.3.	Abbreviations	7
1.4.	Labelling.....	8
1.5.	Contact Address.....	9
2.	About the aentron Lithium-ion Battery	10
2.1.	Using the Lithium-ion Battery	10
2.1.1.	Intended Use	10
2.1.2.	Foreseeable Misuse	10
2.2.	Technical Data	11
2.2.1.	Dimensions	11
2.2.2.	Electrical Specification	12
2.2.3.	Additional Specifications	12
2.2.4.	Ambient Conditions	13
2.2.5.	Standby Current Consumption	14
2.3.	Scope of Delivery	15
2.3.1.	Versions of the Lithium-ion Battery	15
3.	Safety	16
3.1.	Basic Functional Safety.....	16
3.2.	Warnings of a General Nature	17
3.3.	Thermal Hazards.....	18
3.4.	Electrical Hazards	18
3.5.	Dangers Caused by Materials and Substances	18
3.6.	Safety Equipment.....	19
4.	Preparation for Use	20
4.1.	Layout and Controls	20
4.1.1.	LED Definition	21
4.2.	Interfaces External Systems	22
4.3.	Transport and Storage	24
4.3.1.	Unpacking	25
4.4.	Installation	25
4.4.1.	Installation Location of the Lithium-ion Battery	25
4.4.2.	Electrical Connection	26
4.4.3.	Connections CAN Bus (only Type R).....	27

4.4.4.	Checking the Functions.....	27
4.5.	Commissioning.....	28
5.	Operation the Lithium-ion Battery.....	29
5.1.	General	29
5.2.	Modes of Operation.....	29
5.2.1.	Parallel Connection	30
5.3.	Normal Operation.....	31
5.3.1.	Starting as a Stand-Alone Solution	31
5.3.2.	Charging.....	32
5.3.3.	Charging Method.....	33
5.3.4.	Charge Equalisation	33
5.3.5.	Saving Power	33
6.	Maintenance.....	34
6.1.	Operational and maintenance standards for lithium-ion batteries	34
6.2.	Avoidance of deep discharge	34
6.3.	Operational life time	35
6.4.	Cycle life-time.....	36
6.5.	Service and repair	36
6.5.1.	Packaging	36
6.5.2.	Dangerous good labels on the transport box	37
6.5.3.	Transport service provider	38
7.	Cleaning, Maintenance and Care.....	39
7.1.	Cleaning and Care	39
7.2.	Maintenance.....	39
8.	Decommissioning and Disposal	40
8.1.	Decommissioning.....	40
8.2.	Storage.....	41
8.3.	Winter Storage	42
8.4.	Disposal and Recycling.....	42
9.	Faults and Notifications	43
9.1.	Troubleshooting	43
9.2.	Emergencies	45
9.3.	Frequently Asked Questions (FAQ)	45
10.	Legal Information.....	48
10.1.	Warranty Conditions.....	48
10.2.	Copyright and Property Rights	48
10.3.	Material and Legal Defects	49
10.4.	Approvals and EU Declaration of Conformity.....	49



10.5.	EMC	51
11.	Plans	52
11.1.	Maintenance plan	52
11.2.	Maintenance Protocol	53

1. Introduction

1.1. General

This operating manual enables the safe and efficient handling of the aentron lithium-ion battery and describes all the essential functions.

This operating manual ensures the safe operation of the lithium-ion battery in accordance with the intended use.

This document contains:

- Description of the design, functions and features of the lithium-ion battery
- Notes on possible dangers, their consequences and on measures for hazard prevention
- Detailed specifications on the standard operation of the lithium-ion battery.

The operating manual must be stored away safely for users to be able to access at any time. Please read the operating manual carefully before placing the lithium-ion battery into operation.

For the safe and efficient use, all the safety instructions and handling instructions of this operating manual must be read and understood. Furthermore, we recommend following the requirements of EN ISO 16315:2016 for the integration and professional installation of the lithium-ion battery.

In this operating manual, the latest version of the lithium-ion battery is described. If changes or supplements are required in the future, the operating manual is amended, and all amendment are included in the next revision.

The respective version of the operating manual is displayed on the cover sheet and in the footer; this operating manual is version "1.0". The version will be increased by "1" with every revision.

aentron GmbH reserves the right to make changes to systems and documentation without notifying users of previous versions.

TIP



If the lithium-ion battery is passed or sold on to third parties, the following documents must be passed on to the new user:

- ▶ This operating manual
- ▶ Documentation of repair work carried out.

1.2. Terminology

Cell

The cell is the smallest part of an electrochemical storage system and stores the chemical energy.

Module

A grouping of multiple cells or cell blocks, fitted with a battery management system.

Battery

A battery refers to when several modules are connected in parallel or in series.

Battery system

If several modules are connected in parallel or in series and are managed by an energy controller, this is referred to as a battery system.

1.3. Explanation of Symbols

1.3.1. Structure of the Safety Instructions

The safety instructions in this document are presented with a standardised format and symbols. Depending on the probability of occurrence and the severity of the consequences, the following hazard classes are used:

WARNING



Indicates a hazardous situation which could lead to serious physical injury or burns.

- ▶ Measures for preventing the hazard

NOTICE

Indicates a situation that could lead to property damage.

- ▶ Measure for preventing the property damage

TIP



Application tips and particularly useful information

1.3.2. Symbols, Warning Signs and Mandatory Signs



Warning of a hazard point



Warning of electrical voltage



Warning of corrosive substances



Warning of a fire hazard



Application tips and other useful information

Symbols on the Lithium-ion Battery



Pay attention to the manual



Not for disposal with domestic waste



CE mark



ECE R10 mark



UN38.3 mark

1.3.3. Abbreviations

- E-Switch = Electronic switch
- C-Rate = Current to charge the battery in 1 hour
- SoC = State of Charge of the Battery
- DoD = Depth of Discharge
- BMS = Battery Management System
- BLK = Black
- CAN = Controller Area Network / Serial Bus System
- GND = Chassis Ground
- CCCV = Constant Current, Constant Voltage

1.4. Labelling

Every lithium-ion battery from aentron GmbH is fitted with a type plate. This is located on the front / top of the lithium-ion battery.

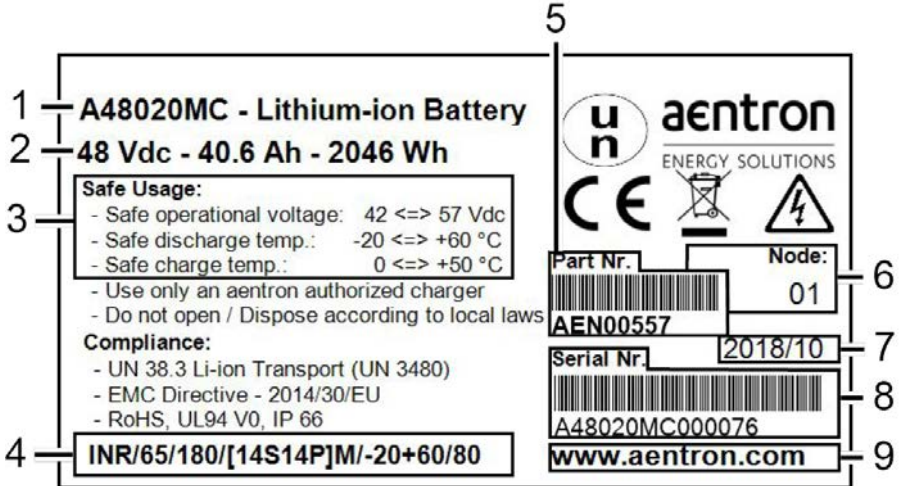

Figure 1: Type Plate M-Type (example)

- 1 Type name
- 2 Voltage, Capacity, Energy
- 3 Safe operating voltage, operating temperature
- 4 Serial number
- 5 Part number
- 6 CAN node ID number
- 7 Production date
- 8 Serial number
- 9 Contact information

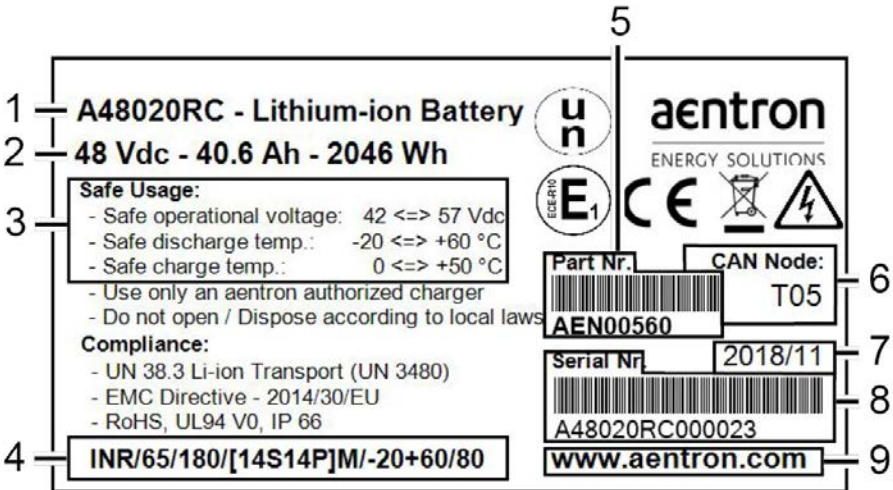

Figure 2: Type plate R-Type (example)

- 1 Type name
- 2 Voltage, Capacity, Energy
- 3 Safe operating voltage, operating temperature
- 4 Serial number
- 5 Part number
- 6 CAN node ID number for 01T = Terminator (only for type R)
- 7 Production date
- 8 Serial number
- 9 Contact information

1.5. Contact Address

aentron GmbH - Energy Solutions
Domierstraße 21
82205 Gilching
GERMANY
Phone: +49 8105 398 98-0
Fax: +49 8105 398 98-29
www.aentron.com
info@aentron.com

2. About the aentron Lithium-ion Battery

2.1. Using the Lithium-ion Battery

The aentron lithium-ion battery has been designed so that it can be used as a modular assembly, either as a single device or in a parallel configuration with other appropriate lithium-ion batteries of the same capacity and power of up to 60 V.

The modular concept of the lithium-ion batteries enables scalable configurations of up to a maximum of 4 modules in parallel of up to 60 Vdc, without a higher-level control system being required. The lithium-ion batteries in conjunction with our integrated Battery Management System (BMS) are therefore designed and configured for high performance and safe operation. Further configuration options are possible in consultation with aentron.

All lithium-ion batteries have galvanic isolation to ground > 1,000 Vdc. Thanks to the integrated BMS, all safety-related parameters of the lithium-ion battery - such as over / undervoltage, over-current, over / under temperature, cable breaks and charge level - are continuously monitored.

2.1.1. Intended Use

The lithium-ion battery is equipped with the latest Li-NMC cell technology and is designed for the following applications:

- E-Industry
- E-Maritime
- E-Mobility
- ON / OFF grid

The lithium-ion battery can be operated as a stand-alone solution or used in a parallel connection with a maximum of 4 x lithium-ion batteries. Should you require greater capacities, please contact your authorised aentron dealer.

The limits to use described in this user manual must always be complied with.

The lithium-ion battery must only be used for purposes described in this user manual.

2.1.2. Foreseeable Misuse

Use of the lithium-ion battery other than or in addition to that described in chapter 2.1.1. Intended Use is considered to be improper use, meaning incorrect use, and this leads to warranty invalidation.

This applies in particular to the use of the lithium-ion battery for applications in medical or aerospace industries.

2.2. Technical Data

The conditions at the location of usage of the lithium-ion battery must match the conditions which are presented as permissible ambient conditions in this operating manual.

aentron GmbH assumes no liability for damage arising from use in different conditions.

2.2.1. Dimensions

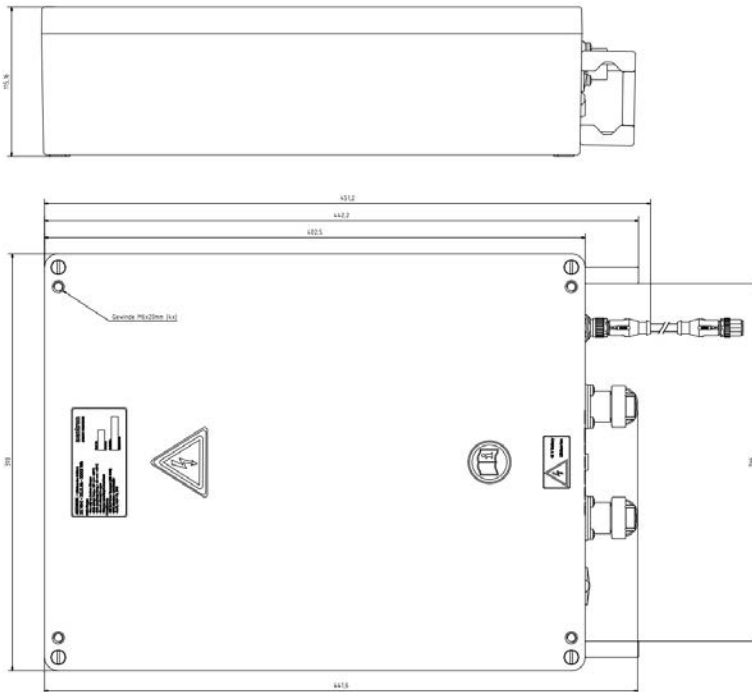

Figure 3: Dimensions lithium-ion battery 2 kWh

12 Vdc / 24 Vdc / 48 Vdc - 2 kWh Li-ion Type M (60 A), Type R (200 A)	
Length [mm]	442,5

Width [mm]	310
Depth [mm]	115
Weight [kg]	approx. 22

2.2.2. Electrical Specification

	12 Vdc / 24 Vdc / 48 Vdc 2 kWh Li-ion Type M (60 A)	12 Vdc / 24 Vdc / 48 Vdc 2 kWh Li-ion Type R (200 A)
Nominal voltage [Vdc]	12 / 24 / 48	12 / 24 / 48
Operating voltage [Vdc]	12 to 16 / 21 to 28 / 42 to 56	12 to 16 / 21 to 28 / 42 to 56
aentron ID	A12020M / A24020M / A48020M	A12020R / A24020R / A48020R
Capacity [Ah]	140 / 80 / 40	140 / 80 / 40
Power [Wh]	2000	2000
Continuous current [A]	60	200
Control system	E-Switch, status LED	E-Switch, CAN bus, status LED

2.2.3. Additional Specifications

	12 Vdc / 24 Vdc / 48 Vdc - 2 kWh Li-ion Type M (60 A), Type R (200 A)
Configuration	Max.: 60 V / 4 x parallel (8 kWh)

Technology	Li-NiCoMnO ₂
Cell balance	Passive (150 mA)
Cooling concept	Passive
Approvals	UN 38.3, CE, RoHS, DNV-GL
Cycles (full)	approx. 3,000 (80 % Kp @ +20 °C)
Fast charging	0.5 - 2 C
Housing material	Aluminium die casting
Feed terminal	RADLOK 10 mm (RED & BLK)

2.2.4. Ambient Conditions

Recommended operating temperature range [°C]	0 to +30
Max. component standby temperature [°C]	+80
Min. operating temperature [°C]	-20
Max. operating temperature [°C]	+60
Charging temperature range [°C]	+0 to +50
Relative humidity [%]	5 - 95
Transport / delivery conditions	-20 °C to +30 °C at 65 % ambient humidity
Ingress protection (IP) class	IP66
UL flammability class	UL94 V0
Operating height [m]	< 4,000

2.2.5. Standby Current Consumption

Type M - Standby current consumption until the lithium-ion battery switches to deep-discharge protection

2 kWh Li-ion - Type M, standby status	Load (W)	SoC (%)	12 Vdc / 24 Vdc / 48 Vdc Time until deep discharge
E-Switch ON	0.05	100	40,000 hours / 1,666 days
E-Switch ON	0.05	50	20,000 hours / 833 days
E-Switch ON	0.05	5	2,000 hours / 83 days
E-Switch ON	0.05	1	400 hours / 16 days

Type R - Standby current consumption until deep-discharge protection is initiated by the lithium-ion battery

2 kWh Li-ion - Type R, standby status	Load (W)	SoC (%)	12 Vdc / 24 Vdc / 48 Vdc Time until deep discharge
E-Switch ON & RELAY CLOSED	4.6	100	420 hours / 17 days
E-Switch ON & RELAY CLOSED	4.6	50	210 hours / 8 days
E-Switch ON & RELAY CLOSED	4.6	5	20 hours
E-Switch ON & RELAY CLOSED	4.6	1	4 hours

2 kWh Li-ion - Type R, standby status	Load (W)	SoC (%)	12 Vdc / 24 Vdc / 48 Vdc Time until deep discharge
E-Switch ON & RELAY OPEN	2.8	100	710 hours / 29 days
E-Switch ON & RELAY OPEN	2.8	50	355 hours / 14 days
E-Switch ON & RELAY OPEN	2.8	5	35 hours
E-Switch ON & RELAY OPEN	2.8	1	7 hours

2 kWh Li-ion - Type R, standby status	Load (W)	SoC (%)	12 Vdc / 24 Vdc / 48 Vdc Time until deep discharge
System OFF	0.05	100	40,000 hours / 1,666 days
System OFF	0.05	50	20,000 hours / 833 days
System OFF	0.05	5	2,000 hours / 83 days
System OFF	0.05	1	400 hours / 16 days

2.3. Scope of Delivery

2 kWh - Type M and R 12 V, 24 V, 48 V

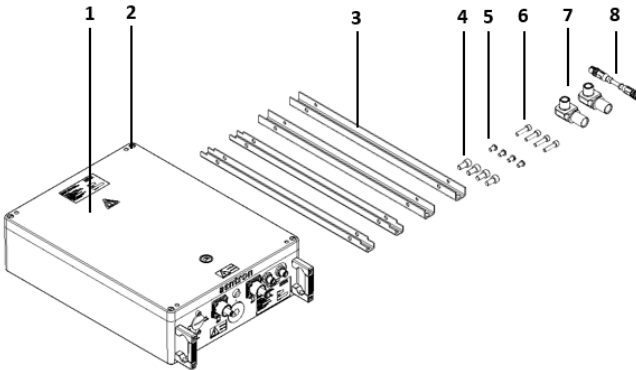

Figure 4: Scope of delivery (2 kWh - Type M and R)

- 1 Energy storage system
- 2 4 x cover mounting holes (M6 x 20 mm)
4 x base mounting holes (M8 x 30 mm)
- 3 Mounting rail set*
- 4 4 x fixing screws (M8 x 16 mm) for horizontal rails*
- 5 4 x fixing screws (M6 x 10 mm) for support rails*
- 6 4 x fixing screws (M6 x 25 mm) for cover rails*
- 7 (+) / (-) Power connection sockets (10 mm)
- 8 Communications cable (8-pin)*

* Optional - Available separately and dependent on the configuration

2.3.1. Versions of the Lithium-ion Battery

Type M - 2 kWh

- A12020M - 12 V - 2 kWh
- A24020M - 24 V - 2 kWh
- A48020M - 48 V - 2 kWh

Type R - 2 kWh

- A12020R - 12 V - 2 kWh
- A24020R - 24 V - 2 kWh
- A48020R - 48 V - 2 kWh

Equipment options:

- Integrated ON / OFF E-Switch or remote switch (remote control)
- CAN bus (only for Type R)

You can find the technical specifications of the individual versions in chapter 2.2. Technical Data.

3. Safety

You can find a detailed explanation of the safety and warning symbols in chapter 1.3. Explanation of Symbols.

Special safety regulations may apply to particular activities. Safety and warning signs for such activities can be found in the respective chapters of this operating manual.

3.1. Basic Functional Safety

For the operation of the lithium-ion battery, safety, accident prevention and environmental protection regulations must also be followed.

Only use the lithium-ion battery:

- For its intended purpose, in a safe and hazard-conscious manner and by paying attention to this operating manual.
- If all safety equipment is present and fully functional.
- If the lithium-ion battery is in a technically flawless condition.

This also includes:

- The warning signs and labels attached on the lithium-ion battery must always be complete and in a legible condition. Replace damaged or illegible signs. Please refer to your authorised aentron dealer.
- Only perform installation, cleaning and / or disassembly work when the lithium-ion battery is switched off.

NOTICE

Physical damage to the lithium-ion battery due to excessive current flow through voltage compensation.

- ▶ Prior to connecting in parallel, measure the respective voltage of the individual lithium-ion batteries.
Make sure that the voltages between the individual lithium-ion batteries DO NOT deviate > 1 Vdc.

3.2. Warnings of a General Nature

- ONLY take the lithium-ion battery out of the original packaging if it is required for use.
- DO NOT subject the lithium-ion battery to any excessive mechanical shocks; e.g. from dropping.
- DO NOT remove the attached handles which are required for preventing accidental drop damage.
- The pressure-equalisation membrane must NOT be blocked or covered. The lithium-ion battery does not need any extra ventilation under normal operating conditions.
- In addition, you should fit your application with an electric fuse which is rated lower than the fuse of the lithium-ion battery (e.g. 10 % to 20 % lower). Please note the technical data of the lithium-ion battery in this regard.
Type M fuse: **63 A**; Type R fuse: **200 A**
- If the internal fuse of the lithium-ion battery fails, please refer to your authorised aentron dealer for support and repairs.
DO NOT attempt to replace the fuse, otherwise the warranty for the lithium-ion battery will be invalidated.
- ONLY use chargers which have been authorised by aentron GmbH.
- Ensure correct polarity when connecting the lithium-ion battery and the charger.
- DO NOT combine or mix different manufacturers, capacities, sizes or types of other battery technologies with the lithium-ion battery.
- ONLY use the lithium-ion battery for the intended application and power; see chapters 2.1.1. Intended Use and 2.2. Technical Data.
- Ensure that the voltages between the individual lithium-ion batteries DO NOT deviate > 1 Vdc for every parallel connection.
- The lithium-ion battery boasts IP protection class 66, and is thus splash-proof. It should, however, not be subjected to wet conditions continuously for its own protection.
- NEVER use a damaged Lithium module.
- When handling and maintaining the Li-ion module use suitable test devices and personal safety clothing, safety gloves and protective eyewear.
- Remove and Store the Lithium module electrically separated and isolate the (+) / (-) battery pole. Pay attention that there are still some voltage on the DC-outputs when the battery module is inactive (OFF).
- Switch the lithium-ion battery off when not in use.
- Store away the original packaging for servicing / repairs / disposal at the end of the service life.

3.3. Thermal Hazards



Risk of fire possible due to overheating of the lithium-ion battery.

- ▶ DO NOT subject the lithium-ion battery to any excessive heat or fire (> +60 °C).
- ▶ Pay attention to the safety instructions attached to the lithium-ion battery.

DO NOT exceed the permissible temperature ranges; see chapter 0.

- ▶ Ambient Conditions.
- ▶ DO NOT leave the lithium-ion battery switched on with exposed terminals. This could lead to a short circuit.
- ▶ In the event of a fire, use a CO₂ fire extinguisher or a fire extinguisher with non-conductive foam. Please proceed as follows:
 - Step 1: **Extinguish** with CO₂ fire extinguisher / fire extinguisher with non-conductive foam
 - Step 2: **Cool** with CO₂ fire extinguisher / fire extinguisher with non-conductive foam
 - Step 3: **Isolate** -> Place the lithium-ion battery in a secure location for at least seven days and also cover it with sand.
- ▶ Remove the lithium-ion battery in the event of a short circuit or overcharge and isolate it for 24 - 48 hours to prevent internal cell short circuit (slow-burn short circuit). Refer to your authorised aentron dealer immediately for further assistance.

3.4. Electrical Hazards



Fatal electric shock possible due to improper handling of the lithium-ion battery.

- ▶ DO NOT attempt to open, repair or disassemble the lithium-ion battery.
- ▶ Repairs must only be performed by specialist personnel authorised by aentron GmbH.

3.5. Dangers Caused by Materials and Substances



Risk of corrosion possible due to the lithium-ion battery leaking.

- ▶ In the event of the lithium-ion battery leaking, the fluid must not come into contact with the skin or the eyes.
- ▶ In the event of contact, rinse the affected area with plenty of water and seek medical attention.

3.6. Safety Equipment

BMS - Battery Management System

Thanks to the integrated BMS, all safety-related parameters of the lithium-ion battery - such as over / undervoltage, over-current, over / under temperature, cable breaks and charge level - are continuously monitored.

Battery Heating System (only for Type R)

For operation at low temperatures below $-10\text{ }^{\circ}\text{C}$, the lithium-ion batteries can optionally be fitted with an internal heating system.

This function is only available for the lithium-ion battery Type R.

Please refer to your authorised aentron dealer for more information.

4. Preparation for Use

4.1. Layout and Controls

2 kWh - Type M and R 12 V, 24 V, 48 V

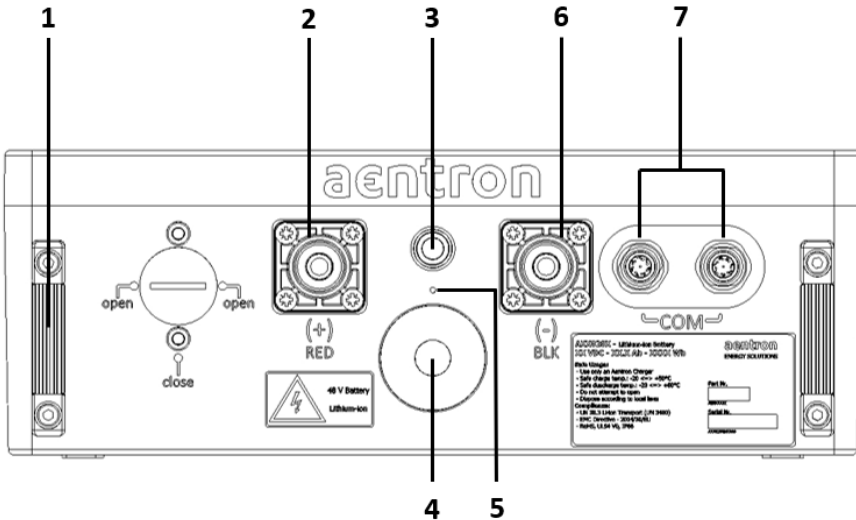

Figure 5: Interfaces and controls (2 kWh Type M+R)

- 1 Handle
- 2 (+) power interface (10 mm)
- 3 Status LED / charge status SoC
- 4 Pressure relief valve
- 5 Pressure-equalisation membrane
- 6 (-) power interface (10 mm)
- 7 2x Conec-connection (8-pin) for interconnection, communication and display-integration*

*when connecting the last module needs a 120 Ohm terminator (SAEN00927)

Power Interface

- (+) terminal; red RADLOK:
10 mm (0 to 1000 V to 200 A) /
-40 to +125 °C

- (-) terminal; blk RADLOK:
10 mm (0 to 1000 V to 200 A) /
-40 to +125 °C

4.1.1. LED Definition

LED	SoC (%)	12 Vdc	24 Vdc	48 Vdc	Mode
flashing red	-5	< 12 V	< 21 V	< 41 V	Shutdown mode / Immediate charging
red	0	> 12 V	> 21 V	> 41 V	Shutdown mode / Battery empty
yellow	20	> 13 V	> 23 V	> 45 V	Warning: charge level low
green	50	> 14 V	> 25 V	> 50 V	Normal operation
flashing green	100	> 15.5 V	> 27 V	> 55 V	Battery full
green / red	105	> 17 V	> 30 V	> 59 V	Battery in overcharged condition / Terminate charging process immediately

4.2. Interfaces External Systems

Parallel Module Configurations: Communication Module - Type M

Type M with optional 8-pin communications connector - maximum 4 x modules connected in parallel with the integrated E-Switch

Function	Signal	Range (Type M)
PIN 1 (white)	-	-
PIN 2 (brown)	-	-
PIN 3 (green)	E-Switch	High / Low
PIN 4 (yellow)	-	-
PIN 5 (gray)	-	-
PIN 6 (pink)	-	-
PIN 7 (blue)	E-Switch	High / Low
PIN 8 (red)	-	-

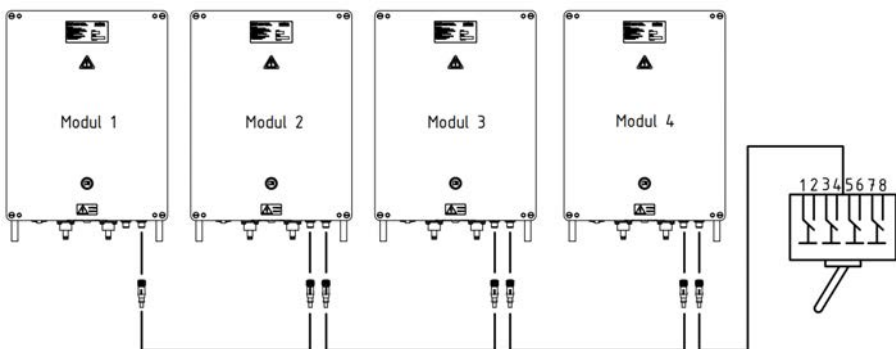

Figure 6: Parallel module configuration (2 kWh - Type M)

Parallel Module Configurations: Module Communication / Type R

Type R with optional 8-pin communications connector - maximum 4 x modules connected in parallel with the integrated E-Switch

Function	Signal	Grey Conec	Green Conec
PIN 1	CAN LOW	White	White / Brown
PIN 2	CAN HIGH	Brown	Brown
PIN 3	GND	Green	Green
PIN 4	12 Vdc + (25 W output)	Yellow	Green / White
PIN 5	-	Grey	Orange
PIN 6	-	Pink	Orange / White
PIN 7	Enable-Switch	Blue	Blue
PIN 8	-	Red	Blue / White

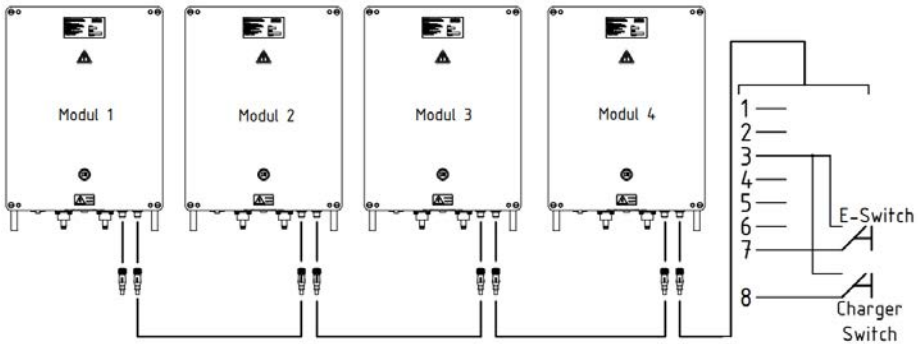

Figure 7: Parallel module configuration (2 kWh - Type R)

4.3. Transport and Storage

WARNING



Risk of fire possible due to overheating of the lithium-ion battery.

- ▶ DO NOT subject the lithium-ion battery to excessive heat or fire (> +60 °C).
- ▶ Avoid storage in areas exposed to direct sunlight.
- ▶ Store the lithium-ion battery in a dry and protected location. Pay attention to the storage conditions; see chapter 0.
- ▶
- ▶ Ambient Conditions.
- ▶ In the event of a fire, use a CO₂ fire extinguisher or a fire extinguisher with non-conductive foam. Please proceed as follows:
 - Step 1: **Extinguish** with CO₂ fire extinguisher / fire extinguisher with non-conductive foam
 - Step 2: **Cool** with CO₂ fire extinguisher / fire extinguisher with non-conductive foam
 - Step 3: **Isolate** -> Place the lithium-ion battery in a secure location for at least seven days and also cover it with sand.
- ▶ Remove the lithium-ion battery in the event of a short circuit or overcharge and isolate it for 24 - 48 hours to prevent internal cell short circuit (slow-burn short circuit).

The lithium-ion battery is transported in accordance with the requirements of UN38.3 on the transport of dangerous goods.

Store away the original packaging for servicing / repairs / disposal at the end of the service life.

In case of any doubt, please refer to your authorised aentron dealer.

TIP



Shipping a lithium-ion battery without approved packaging may lead to penalties and fines.

Store the lithium-ion battery in the original packaging in a dry and protected location. Observe the transport / storage conditions:
-20 °C to +30°C at 65 % ambient humidity

4.3.1. Unpacking

Immediately after delivery, check the condition of the lithium-ion battery and all electrical interfaces for damage. Check the completeness of the delivery using the delivery note.

Record any transport damage in writing and report this immediately to the freight forwarder and aentron GmbH or your authorised aentron dealer.

4.4. Installation

4.4.1. Installation Location of the Lithium-ion Battery

For the location of installation of the lithium-ion battery, please pay attention to the ambient conditions; see chapter 0.

Ambient Conditions.

The lithium-ion battery has 4 x mounting holes, both on the cover and on the base of the module (see **Fehler! Verweisquelle konnte nicht gefunden werden.**).

Fix the lithium-ion battery using the mounting holes, fixing screws and, if necessary, the mounting rail sets.

The lithium-ion battery can be installed in any angle of orientation.

The mounting rail set is an optional extra and is available separately if required. For further information, please refer to your authorised aentron dealer.

4.4.2. Electrical Connection

WARNING



Fatal electric shock possible due to improper handling of the lithium-ion battery.

- ▶ DO NOT connect the lithium-ion battery to an AC power source.
- ▶ DO NOT connect the lithium-ion battery in series > 60 Vdc.
- ▶ Pay attention to the (+) and (-) marks on the lithium-ion battery.
- ▶ During installation, first connect the (+) pole and then the (-) pole, to prevent excessive electrostatic discharge (sparks).
- ▶ Fit your application with an electric fuse which is rated lower than the fuse of the lithium-ion battery (e.g. 10 % to 20 % lower). Please note the technical data of the lithium-ion battery in this regard. Type M fuse: **63 A**; Type R fuse: **200 A**
- ▶ If the internal fuse of the lithium-ion battery fails, please refer to your authorised aentron dealer for support and repairs. DO NOT attempt to replace the fuse, otherwise the warranty for the lithium-ion battery will be invalidated.

NOTICE

Physical damage to the lithium-ion battery due to excessive current flow through voltage compensation.

- ▶ Prior to connecting in parallel, measure the respective voltage of the individual lithium-ion batteries. Make sure that the voltages between the individual lithium-ion batteries DO NOT deviate > 1 Vdc.

To connect the lithium-ion battery, please proceed as follows:

1. Make sure that the lithium-ion battery is switched off and the status LED is NOT illuminated.
 2. Connect the supplied (+) RED cable to the correspondingly marked (+) RED power terminal.
 3. Connect the supplied (-) BLK cable to the correspondingly marked (-) BLK power terminal.
 4. Make sure that the RADLOK connectors latch in correctly so that a secure electrical connection is ensured.
 5. Set the power switch to ON.
- ➔ The status LED lights up in accordance with the current charge level after 2 seconds.
- ✓ The lithium-ion battery is ready for operation.

4.4.3. Connections CAN Bus (only Type R)

Type R is equipped with the CANopen protocol.

When delivered from the factory, the CAN bus speed is set to 250 kbit/s by default.

Type R boasts numerous settings options and functions which you can adjust. You can find further technical information and support on this at www.aentron.com/en/downloads/product-information

TIP



If the lithium-ion battery is NOT equipped with the integrated ON / OFF power switch, use the communications cable supplied as an alternative.

To connect the lithium-ion battery via a CAN bus, proceed as follows:

1. Connect PIN 3 (GND) and PIN 7 (E-Switch) with a switch (remote-controlled) in order to be able to switch the lithium-ion battery on/off.

NOTICE

Physical damage to the lithium-ion battery possible due to incorrect operation.

- ▶ When energy storage systems equipped with CAN bus are integrated, one must ensure that a 120 ohm terminating resistor is at the end of the communications chain (applies to Type R).
2. Install the terminating resistor required for your CAN bus.
 3. Connect PIN 1 (CAN LOW) and PIN 2 (CAN HIGH) with the CAN bus for communication of up to 250 kbit/s.
 4. Before starting the charging process, make sure that you are using a charger with a 4-pin assignment authorised by aentron GmbH. If the charger is switched on, a connection should be established between PIN 8 (charge switch) and PIN 3 (GND). This automatically wakes the lithium-ion battery and prevents the discharging function. The discharge function of the lithium-ion battery is deactivated while the charger is connected.
- ✓ The energy storage system is connected via a CAN bus.

4.4.4. Checking the Functions

To check the functionality of your lithium-ion battery, proceed as follows:

1. Switch the lithium-ion battery on.

- ➔ The status LED lights up in accordance with the current charge level after 2 seconds.
The status LED should light up either yellow or green.
- 2. Use a multimeter to check that the voltage is within the delivery range defined in the following table.

LED	SoC (%)	12 Vdc	24 Vdc	48 Vdc
yellow	20	≥ 13 V	≥ 23 V	≥ 45 V
green	50	≤ 14 V	≤ 25 V	≤ 50 V

- ➔ If the voltage deviates from the defined range, refer to your authorised aentron dealer.
- ➔ If the voltage is in the defined range, the lithium-ion battery can be used.
- ✓ The function check is complete.

4.5. Commissioning

In order to put your lithium-ion battery into operation, proceed as follows:

1. Switch the lithium-ion battery on.
 - ➔ The status LED lights up in accordance with the current charge level after 2 seconds.
The status LED should light up either yellow or green.
2. Use a multimeter to check that the voltage is within the delivery range defined in the following table.

LED	SoC (%)	12 Vdc	24 Vdc	48 Vdc
yellow	20	≥ 13 V	≥ 23 V	≥ 45 V
green	50	≤ 14 V	≤ 25 V	≤ 50 V

- ➔ If the voltage deviates from the defined range, refer to your authorised aentron dealer.
- ➔ If the voltage is in the defined range, the lithium-ion battery can be used.
- 3. Charge the lithium-ion battery completely before using it.
- ✓ The lithium-ion battery is ready for operation.

5. Operation the Lithium-ion Battery

5.1. General

WARNING



Risk of fire possible due to overheating of the lithium-ion battery.

- ▶ Operate the lithium-ion battery exclusively in accordance with the electrical specifications and the ambient conditions; see chapter 2.2. Technical Data.
- ▶ DO NOT use the lithium-ion battery in a combustion engine chamber.
- ▶ Avoid operation of the lithium-ion battery in temperatures $> +40\text{ °C}$, as this could lead to premature ageing of the lithium-ion battery.
- ▶ Ensure the charging temperature range of 0 °C to $+45\text{ °C}$.

NOTICE

Physical damage to the lithium-ion battery due to incorrect operation.

- ▶ When lithium-ion batteries equipped with CAN bus are integrated, one must ensure that a 120 ohm terminating resistor is at the end of the communications chain (applies to Type R).

5.2. Modes of Operation

Normal Operating Mode

The lithium-ion battery is in normal mode when it responds to electrical charging and load currents.

Safety Mode

The lithium-ion battery is in safety mode when the BMS detects over / undervoltage, over-current, over / under temperature or a short circuit.

The function of the lithium-ion battery is blocked until the condition over / undervoltage is resolved.

Shutdown Mode

In shutdown mode, the lithium-ion battery stops all normal functions and there is no power at the feed terminal.

5.2.1. Parallel Connection

NOTICE

Physical damage to the lithium-ion battery due to excessive current flow through voltage compensation.

- ▶ Prior to connecting in parallel, measure the respective voltage of the individual lithium-ion batteries. Make sure that the voltages between the individual lithium-ion batteries DO NOT deviate > 1 Vdc.

Make sure that the lithium-ion batteries are connected so that the current is distributed evenly to the lithium-ion batteries; see connection figure 8.

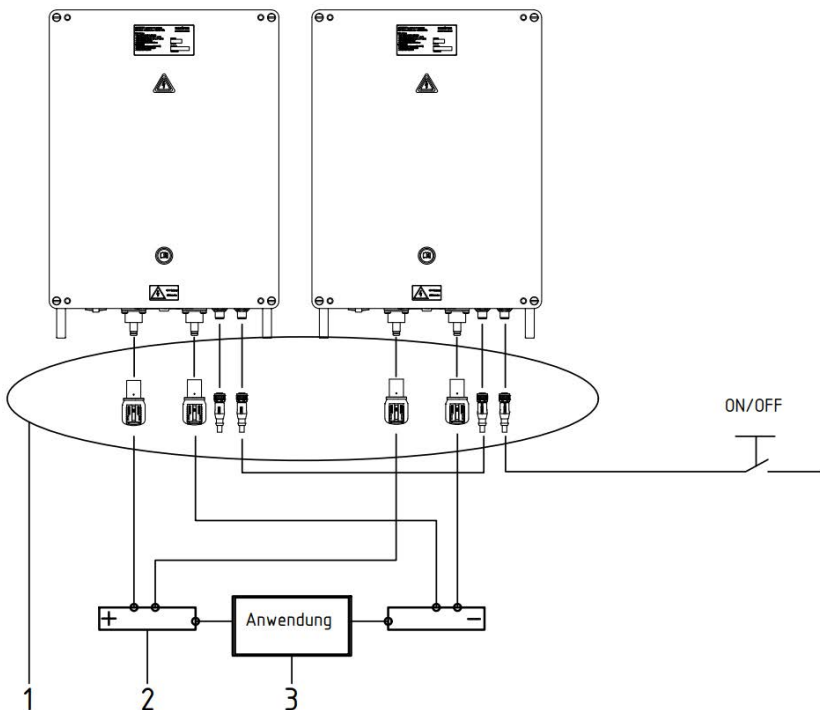

Figure 8: Parallel connection (2 kWh Type M and R)

- 1 Component ports
- 2 Busbar
- 3 Consumer

5.3. Normal Operation

5.3.1. Starting as a Stand-Alone Solution

To start your lithium-ion battery as a stand-alone solution, proceed as follows:

1. Switch the lithium-ion battery on.
→ The status LED lights up in accordance with the current charge level after 2 seconds.
The status LED should light up either yellow or green.
2. Use a multimeter to check that the voltage is within the delivery range defined in the following table.

LED	SoC (%)	12 Vdc	24 Vdc	48 Vdc
yellow	20	≥ 13 V	≥ 23 V	≥ 45 V
green	50	≤ 14 V	≤ 25 V	≤ 50 V

- If the voltage deviates from the defined range, refer to your authorised aentron dealer.
- If the voltage is in the defined range, the lithium-ion battery can be used.
3. Charge the lithium-ion battery completely before using it.
- ✓ The lithium-ion battery is ready for operation.

5.3.2. Charging

TIP



Secondary cells and lithium-ion batteries must be charged before use. **ONLY** use chargers which have been authorised by aentron GmbH. Make sure that you use an appropriate charger based on the battery voltage of your lithium-ion battery; see table.

Rated voltage	Umin charge	Umax charge
12 Vdc	12 V	16 V
24 Vdc	21 V	28 V
48 Vdc	42 V	56 V

To charge the lithium-ion battery, proceed as follows:

1. Make sure to use a charger authorised by aentron GmbH.
2. Make sure that the lithium-ion battery is switched off and the status LED is NOT illuminated.
3. Connect the supplied (+) RED cable to the correspondingly marked (+) RED power terminal.
4. Connect the supplied (-) BLK cable to the correspondingly marked (-) BLK power terminal.
5. Make sure that the RADLOK connectors latch in correctly so that a secure electrical connection is ensured.
6. Set the power switch to ON.
 - ➔ The status LED lights up in accordance with the current charge level after 2 seconds.
7. Switch the charger on.
 - ➔ The charging process starts automatically within 5 seconds. The charging process terminates automatically once the process is complete.
 - ✓ The lithium-ion battery is fully charged. The status LED flashes green.

5.3.3. Charging Method

The lithium-ion batteries are optimally charged based on the CCCV method at an ideal temperature of +10 °C to +30 °C.

Furthermore, all chargers recommended by aentron GmbH are fitted with a float charging function with a maximum float delta of 1 V. This ensures that the lithium-ion battery is always fully charged and that the long-term strain of the lithium-ion battery is minimised at high SoC values.

5.3.4. Charge Equalisation

After switching off the lithium-ion battery, the power terminals (+) and (-) are electrostatically discharged to 0 Vdc within ten seconds.

5.3.5. Saving Power

The lithium-ion battery Type M has low self-discharge (< 0.05 W). Nevertheless, we recommend switching off the lithium-ion battery or connecting it to a charger when it is not in use.

The optimum long-term storage range is a SoC of between 30 % to 50 %.

TIP



With the Type R lithium-ion batteries, due to the integrated electronics (relay, LEM, CAN bus with internal supply), there is a risk of the function becoming impaired after lengthy downtimes (standby current consumption = 4.6 W; see table Standby Current Consumption page 14).

We recommend switching the lithium-ion battery off when not in use or connecting it to a charger to counteract the deep-discharge process.

6. Maintenance

WARNUNG



Fatal electric shock possible due to improper handling of the lithium-ion battery.



- ▶ When handling and maintaining the lithium-ion battery use suitable test devices and personal safety clothing, safety gloves and protective eyewear.



6.1. Operational and maintenance standards for lithium-ion batteries

The lithium-ion battery is a low-maintenance.

We strongly recommend to conduct a yearly calibration and inspection as well as check the system in accordance to the DGUV regulation 3 (BGV A3) and the DIN VDE 0113, to ensure a reliable and safe operation of the lithium-ion batteries.

6.2. Avoidance of deep discharge

Turn off the lithium-ion battery when not using the batteries for extended periods, to avoid a deep discharge of the module.

aentron GmbH has implemented extensive hard- and software functions, to prevent the modules entering a deep discharge mode.

The user is nevertheless obligated, to avoid a deep discharge through appropriate operational procedures.

The lithium-ion battery shall operate in three different operating statuses:

Battery mode	Contactor mode	Control interface
Discharging Mode (ON)	Contactor "CLOSED" / 12 V DC Power ON	E-Switch
Inactive Mode (OFF)	Contactor "OPEN" / 12 V DC Power OFF	E-Switch

Do NOT let the lithium-ion battery be on standby or unsupervised for extensive periods of time (active status – contactor closed).

The internal 12 V DC power supply when left on and unattended can bring the lithium-ion battery in a deep discharge protection mode within days or weeks (Discharge power dependend of the usable capacity)

If a lithium-ion battery reaches the deep discharge- protection mode, it is considered as an „abuse“ by aentron. At the second time the warranty expires (chapter 10.1 Warranty conditions).

To bring the battery into operational mode, an aentron- customer service is required.

Information of the wintering and long-term storage of the battery can be found in chapter 8.3 Winter Storage.

TIPP



Turn off the lithium-ion battery when not in use or connect the battery to a charger, to counteract a deep discharge.

6.3. Operational life time

The average lifetime of a lithium-ion battery is depending on the usage and the environmental temperature. The life time estimation can be referred to in the sales contract.

We do not recommend a float- charging method for the lithium-ion batteries, as a constant charging current decomposes the surface layer of the electrode and the electrolyte that over time accelerates the aging of the battery and leading to reduced cycle life time. The recommended and preferred charging method for a rechargeable lithium-ion battery is a modified CCCV-charger (Constant Current / Constant Voltage), as shown in figure 9.

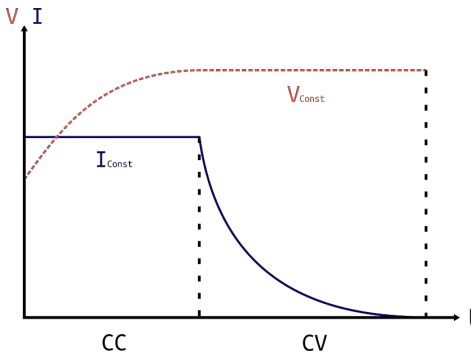

Figure 9: CCCV-charging method

For further information contact your aentron-dealer.

6.4. Cycle life-time

A charge cycle is defined as a full charge and discharge of a lithium-ion battery. Rechargeable lithium-ion batteries have a limited life-time and lose capacity gradually.

This loss of capacity (aging) is irreversible, as lithium atoms are permanently locked in the anode in every “cycle”.

As the lithium-ion battery loses capacity, the power of the battery is reduced (duration / capacity).

Lithium-ion batteries self-discharge very slow (self-discharge 1-2% per month / in the inactive mode), or stored. Regularly check the state of charge of the lithium-ion battery. Please follow the aentron charging recommendations, shown in chapter 4.4.4 *Checking the functions* and ***Fehler! Verweisquelle konnte nicht gefunden werden.*** Charge.

6.5. Service and repair

If the lithium-ion battery requires to be serviced within the warranty time, contact your aentron-dealer.

Remove all the devices before shipping to aentron GmbH.

For service or repair, please send the lithium-ion battery to an aentron designated dealer.

Please note that the transport of the lithium must be conducted with an authorized UN38.3 ADR suitable transport-box. Please consult our AGBs at www.aentron.com/terms-amp-conditions/.

6.5.1. Packaging

Please use/retain, if possible, the original transport-box of aentron GmbH for the product return. The aentron transport-box meets the required quality and has the required ADR symbols for the product return.

Tip: Save the original transport-box until the end of your warranty time.

Please note the packaging information:

- Pack and ship multiple dangerous goods always in separate transport boxes.
- Ensure that the chosen transport box is sufficiently solid and robust.
- Ensure that the product cannot move around inside the transport box and ensure an unintended activation of the battery

- Place the product in the center of the transport box and fill the empty space with non-conductive filling-material, to prevent a shifting or moving of the product during the transport.
- Remove your own plus/ interfaces.
- Isolate the battery poles (protection against a short circuit – otherwise there is a risk of fire or an explosion).

TIPP



Use the filling material of the original transport box or use wrinkled newspaper.

DANGER



Risk of acid burns due to a leakage of lithium-ion battery possible.

- ▶ NEVER ship seriously damaged lithium-ion batteries.
- ▶ If a battery is leaking, avoid skin and eye contact with the liquid.
- ▶ If you cannot avoid contact immediately rinse the affected area with water and contact your doctor.

NEVER ship a severely damaged lithium-ion battery.

- A damaged or heavily deformed housing,
- Temperature increase of the lithium-ion battery in inactive mode.

6.5.2. Dangerous good labels on the transport box

Original transport box of aentron GmbH

On the original transport box you can find all the relevant labels . If the labels are legible, nothing else has to be considered.

Other transport boxes or labels on the original transport box are not legible

If you use a new transport box or the labels and the original transport box is not legible, please implement the following:

- Contact aentron GmbH at service@aentron.com
- Download at www.aentron.com/download/service the relevant labels for the return of dangerous goods.
- Print the labels and put them on the longitudinal side of the transport box.

6.5.3. Transport service provider

Our customer service will provide you with the required information for the return. If you have further questions to the topic „return of dangerous goods “, our customer service is available

- Tel.: +49 8105 398 98-0 workdays from 09:00 to 16:00
- info@aentron.com

7. Cleaning, Maintenance and Care

7.1. Cleaning and Care

NOTICE

Physical damage to the lithium-ion battery possible due to incorrect cleaning.

- ▶ NEVER use petrol, thinning agents, alcohol or other solvents. Otherwise discolouration and / or deformation may occur.

Cleaning must be performed based on the degree of soiling:

1. Switch the lithium-ion battery off.
 2. Disconnect all electrical connections to the lithium-ion battery.
 3. Clean the lithium-ion battery terminals with a clean, dry, lint-free cloth.
 4. Check the housing of the energy storage system for damage.
- ✓ The cleaning is complete.

7.2. Maintenance

Watch and note the operating time as well as the SoH, a „new“ fully charged lithium-ion battery for the power supply supplies your application. Use this „new“ operating time as the base for later comparisons of the operating time. The operating time of the lithium-ion battery depends on the configuration of the battery and on the applications they are used for.

- Constantly check the SoC and the SoH of the lithium-ion battery.
- Carefully check the lithium-ion battery, when the end of the estimated life-time comes closer, e.g. < 60% SoH.
- Exchange the lithium-ion battery, as soon as one of the following conditions appear:
 - The operating time goes below 60% of the initially operating time and the SoH-value.
 - The charging time extends significant.
- Switch off the lithium-ion battery when it is not in use or connect it with a charger, to counteract a deep discharge.

8. Decommissioning and Disposal

8.1. Decommissioning

WARNING



Fatal electric shock possible due to improper handling of the lithium-ion battery.

- ▶ During decommissioning, first disconnect the (-) pole and then the (+) pole, to prevent excessive electrostatic discharge (sparks).
- ▶ Insulate the electrical ports with sticky tape once the lithium-ion battery has reached the end of its service life.

To decommission the lithium-ion battery, proceed as follows:

1. Make sure that the lithium-ion battery is switched off and the status LED is NOT illuminated.
2. Remove the (-) BLK cable from the power terminal (-) BLK.
3. Remove the (+) RED cable from the power terminal (+) RED.
- ➔ The electrical connection of the lithium-ion battery has been removed.
4. If necessary, remove the CAN bus connections.
5. Remove the lithium-ion battery from the mounting rail set.
6. If necessary, disassemble the mounting rail set.
- ✓ The lithium-ion battery has been decommissioned.

8.2. Storage

TIP



When storing for over twelve months, charge the lithium-ion battery up to a minimum of 50 % SoC (status LED = constant green).

- Clean the lithium-ion battery and the electrical ports with a clean, dry, lint-free cloth.
- Pack the lithium-ion battery in the original packaging.
- When putting into storage, note the transport / storage conditions; see chapter 0.
-
- *Ambient Conditions.*

WARNING



Risk of fire possible due to overheating of the lithium-ion battery.

- ▶ DO NOT subject the lithium-ion battery to excessive heat or fire (> +60 °C).
- ▶ Avoid storage in areas exposed to direct sunlight.
- ▶ Store the lithium-ion battery in a dry and protected location. Pay attention to the storage conditions; see chapter 0.
- ▶
- ▶ *Ambient Conditions.*
- ▶ In the event of a fire, use a CO₂ fire extinguisher or a fire extinguisher with non-conductive foam. Please proceed as follows:
 - Step 1: **Extinguish** with CO₂ fire extinguisher / fire extinguisher with non-conductive foam
 - Step 2: **Cool** with CO₂ fire extinguisher / fire extinguisher with non-conductive foam
 - Step 3: **Isolate** -> Place the lithium-ion battery in a secure location for at least seven days and also cover it with sand.

8.3. Winter Storage

The winter storage process is primarily focussed on maritime and outdoor applications.

The lithium-ion battery can be operated between -20 °C to +60 °C.

For applications in which temperatures fall below 0 °C and application operation is shut down (e.g. in maritime applications), we recommend a winter storage process.

The lithium-ion battery can stay in its installation location for the duration of the winter at temperatures down to -20 °C (low-temperature periods).

If ambient temperatures drop below -20 °C, this could lead to premature ageing of the lithium-ion battery. For this reason, the lithium-ion battery should be stored in a temperature-controlled environment between 0 °C to +30 °C.

For winter storage, please proceed as follows:

1. Charge the lithium-ion battery between 50 % to 80 % SoC (enables a storage time of at least two years).
 2. Set the power switch to "OFF".
 3. If necessary, remove the (+) / (-) power cable.
- ✓ The lithium-ion battery is now ready to be stored over the winter period.

8.4. Disposal and Recycling

Once the lithium-ion battery has reached the end of its service life, its safe and professional disposal must be ensured during decommissioning, especially with respect to parts or substances harmful to the environment.

Dispose of the lithium-ion battery in a proper manner in accordance with local statutory regulations and rules governing lithium-ion technologies. To prevent environmental hazards, an approved specialist contractor must be commissioned with disposal. NEVER dispose of the lithium-ion battery in domestic waste / residual waste.

Dispose of materials which can be sent for recycling properly, always keeping our environment in mind.

9. Faults and Notifications

9.1. Troubleshooting

Fault	Cause	Remedy
The battery is not discharging	Battery voltage is within the operating voltage range: 12 V: 12 to 16 Vdc 24 V: 21 to 28 Vdc 48 V: 42 to 56 Vdc	Check that the power cables are properly connected.
	The status LED is either yellow or green.	Check that the power cables are properly connected.
	The battery is in shutdown mode. The status LED is not illuminated.	Switch the battery on at the E-Switch.
	The status LED is red or flashes red. Undervoltage warning	Charge the battery.
	The battery is in safety mode. a) Battery experiencing over temperature: > +60 °C b) Battery experiencing under temperature: < -10 °C	a) Allow the battery to cool down to < +40 °C b) Heat up the battery to > 0 °C
	With the E-Switch activated, the battery is still at 0 V and battery-charging is attempted.	The fuse has blown. Refer to your authorised aentron dealer.
During the charging process, the battery becomes hot (> +50 °C)	Lithium-ion Battery cells are damaged.	Stop the charging process immediately. Isolate the battery for > 24 hours as a preventive measure. Refer to your authorised aentron dealer.
During the discharge process, the battery becomes hot (> +50 °C)	Lithium-ion Battery cells are damaged.	Reduce load current immediately or stop for 15 minutes so that the battery can cool down (< +40 °C). Isolate battery for > 24 hours as a preventive measure. Refer to your authorised aentron dealer.

Fault	Cause	Remedy
The battery stops unexpectedly, even though the status LED is green.	Threshold exceeded a) Over-current (> 60 A (M) / 200 A (R)) b) Over temperature (> +60 °C)	a) Switch off the load and wait 60 seconds. Switch the battery back on again. b) Keep the battery away from heat sources (e.g. engine rooms).
The battery stops unexpectedly, even though the status LED is yellow.	Threshold exceeded a) Over-current (> 60 A (M) / 200 A (R)) b) Over temperature (> +60 °C) c) Undervoltage	a) Switch off the load and wait 60 seconds. Switch the battery back on again. b) Keep the battery away from heat sources (e.g. engine rooms). c) Reduce the load current to a value which prevents the undervoltage level from being exceeded, or charge the battery.
The battery capacity degrades faster than expected.	Premature ageing is caused by: a) Operation at low temperatures (< -10 °C) b) Operation at high temperatures (> +40 °C) c) Mean operational discharge current is above the C-rate d) The average charge current is above 1 C.	a) Prevent prolonged operation below 0 °C. b) Prevent prolonged operation above +40 °C. c) With average operating current, keep to the values of a maximum of 0.7 C as much as possible. d) The average charge current should not be more than 0.5 C.

9.2. Emergencies

Switch the lithium-ion battery off and disconnect all electrical connections:

- In the event of injury.
- If there is a risk that the lithium-ion battery will be damaged.

In the event of an accident, take immediate measures and call the local emergency services number.

In the event of a fire, use a CO₂ fire extinguisher or a fire extinguisher with non-conductive foam. Please proceed as follows:

- **Step 1: Extinguish** with CO₂ fire extinguisher / fire extinguisher with non-conductive foam
- **Step 2: Cool** with CO₂ fire extinguisher / fire extinguisher with non-conductive foam
- **Step 3: Isolate** -> Place the lithium-ion battery in a secure location for at least seven days and also cover it with sand.

Remove the lithium-ion battery in the event of a short circuit or overcharge and isolate it for 24 - 48 hours to prevent internal cell short circuit (slow-burn short circuit).

9.3. Frequently Asked Questions (FAQ)

What is the best way to put the lithium-ion battery into operation?

- aentron lithium-ion batteries are delivered with a charge level of between 30 % to 50 % SoC, and must be fully charged prior to use.
- It is normal for the battery to feel warm to touch during charging and discharging.

How maintenance-intensive is the lithium-ion battery?

- Under normal operating conditions and moderate ambient conditions, aentron lithium-ion batteries are maintenance-free.

What is the lithium-ion chemistry of the lithium-ion battery?

- aentron lithium-ion batteries are based on nickel manganese cobalt chemistry (NMC).
- Li-NMC delivers approx. 70 % more energy density compared to lithium-iron-phosphate formulae (LiFePO₄).

Can the lithium-ion batteries be installed in any location?

- Yes. Mounting holes are provided and a mounting rail set is available as an optional extra.

Can the lithium-ion batteries withstand vibrations and shocks?

- Yes. Our customer's areas of application range from boats to off-road vehicles. The lithium-ion batteries are encased with aluminium die-cast housings.

What is the service life of a lithium-ion battery?

- Service life depends on the application. In general, aentron lithium-ion batteries have a service life of more than ten years. A requirement for this is operation within the permissible voltage range (max. 80 % discharge depth) at room temperature.
- aentron lithium-ion batteries can perform around 3,000 complete charge/discharge cycles (with a max. discharge depth of 80 %).
- To ensure as long a service life as possible, extreme temperatures should be avoided during operation (extreme cold or heat).
- You reach the maximum service life in a SoC range of between 20 % and 90 %.

I heard that lithium-ion batteries are unstable and pose a fire hazard.

aentron lithium-ion batteries are safe, robust and fitted with safety features that go beyond industry standards:

- Waterproof housing
- Robust aluminium die-cast housing
- Battery management system integrated as standard
- Innovative cooling system for the cells
- High-grade cells
- Fire-resistant components
- Units have been tested and have fulfilled all current industry standards and regulations.

How high is the rate of self-discharge for lithium-ion batteries?

- Self-discharge is the loss of usable capacity of a battery due to internal chemical reactions. Self-discharge takes place in all battery chemicals and is influenced by temperature. Self-discharge occurs regardless of whether a battery is connected to a device or not.
- When an aentron lithium-ion battery is switched off, the average rate of self-discharge is 1 to 2 % per month.
- We recommend charging the battery to a charge level of at least 50 % once per year. 2-year storage capability is guaranteed ex works, in any case.

What are the best operation and storage temperatures?

- Temperature fluctuations can have a dramatic effect on the performance and service life of every battery. High temperatures ($> +40\text{ °C}$) intensify the chemical reactions inside the battery and can lead to premature ageing of the battery. Low temperatures ($< 10\text{ °C}$) can slow down chemical processes so much that battery performance might not meet the requirements of the load.
- Ideally, batteries should be stored / charged at 50 % to 80 % SoC between $+10\text{ °C}$ to 25 °C and operated at 0 °C to $+30\text{ °C}$.

How do I maximise battery service life?

- Always store the battery in a cool and dry place. Ensure that the battery is charged to 50 % to 80 % SoC before storing it for long periods.

How do I dispose of the lithium-ion battery?

- aentron lithium-ion batteries are wholly recyclable.

Do the lithium-ion batteries require cell balancing?

- All lithium-ion batteries from aentron GmbH boast integrated, passive cell balancing as standard.
- Cell balancing ensures for maximum performance of the lithium-ion battery and maximises service life.

Do the lithium-ion batteries require special handling during transport?

- Yes. All lithium-ion batteries are considered to be dangerous goods.
- In all other respects, the battery does not require any special treatment beyond the customary preventive measures.

10. Legal Information

10.1. Warranty Conditions

Please observe our warranty conditions and T&Cs at www.aentron.com/en/agb

aentron GmbH is not liable for damages incurred in the case of untrained, inappropriate application, incorrect customer assembly, incorrect commissioning, unauthorized modifications, changes or repairs conducted by the customer and/or third parties. Furthermore, aentron is not liable for normal product wear and tear, the incorrect installation, replacement of materials or components by the customer or third parties, as well as unforeseen electromechanical / electrical (EMC) influences, as long as they are not caused by the aentron GmbH product. aentron GmbH is not liable for defects caused by inappropriate handling, storage or similar by the customer.

For all aentron products – arbitrary, unauthorized modifications, opening, additions, reconstruction / removing, installation of parts that are conducted other than by aentron GmbH trained personal will immediately loss of the warranty claim. When claiming guarantee regress, the customer within statutory limits is allowed to proof that the defects are not caused by any of the above mentioned actions or causes.

The transport, material, insurance or repair costs which are incurred through modification or repair shall be covered by the customer.

10.2. Copyright and Property Rights

All the content of this operating manual is the intellectual property of aentron GmbH and is subject to protection under copyright law.

The product and the word / figurative marks are legally protected.

All reproduction, editing, distribution, handover to third parties, even just excerpts, and any form of exploitation beyond the limits of copyright law require the written consent of aentron GmbH.

In the event of any infringements, aentron GmbH reserves the right to take legal action.

We reserve the right to make changes to this operating manual and changes to technical details in terms of the specifications and illustrations in this operating manual.

All names of products referred to in this operating manual are trademarks of the respective companies and are recognised as such.

10.3. Material and Legal Defects

Claims of the operator concerning material and legal defects require that such complaints be raised in writing without delay, but within two working days at the latest.

aentron GmbH assumes no liability for damage caused by:

- Misuse or non-observance of the operating manual and / or the requirements therein.
- Misuse or damage caused by improper handling, transport, storage or repackaging which was not provided or arranged by aentron GmbH.
- Modifications or repairs to the lithium-ion battery which are not authorised by aentron GmbH.
- Corrosion due to the effect of aggressive atmospheres or environmental conditions beyond the permissible operating and ambient conditions.
- Non-observance of the applicable safety regulations.
- Aesthetic or superficial faults which impair neither the form, value nor functioning of the product.

If aentron GmbH is responsible for a defect, aentron GmbH is entitled to provide subsequent improvement or supply a replacement at its discretion.

No claims are made as to the ability to supply previous versions or the ability to upgrade delivered devices to the latest version.

10.4. Approvals and EU Declaration of Conformity

The Declaration of Conformity and other documents can be found at www.aentron.com/certificates

Approvals	
UN Manual of Tests and Criteria for the Transport of Lithium-Ion Batteries	UN Manual of Tests and Criteria Part III, Sub-Section 38.3 (DGR 3.9.2.2.6)
IATA Transport	SP 188 / PI965, Part II IATA, packaging instructions
IATA Transport	SP 230, special regulation
IP 66 (IEC 60529)	≥ IP67X (IEC60529) [DIN 40050-9]
Environmental compatibility	Directive 2013/56/EC of the Council, compliance with EU environment regulations
IEC 60068-2-2-27	Environmental Audit - Part 2-27: Tests

Approvals	
EMC	Directive 2014/30/EC of the Council on electromagnetic compatibility
IEC 61000 -4-2,3,4,4,5,6,6,7,8,11	Electromagnetic Compatibility (EMC)
IEC 62281	Safety or primary and secondary lithium cells and batteries during transport
IEC 62619	Safety requirements for secondary lithium cells and batteries for use in industrial applications
Low-Voltage Directive (2014/35/EC)	Ensures that all electric operating equipment is within given voltage limits
2006/42/EC	Machinery Directive
95/465/EEC	E-marking - Harmonisation of legal regulations of member states concerning electrical operating equipment intended for use within given voltage limits.
UV assessment	UV assessment (ASTM D 2565) (not legally binding)
IEC 60707 (UL 94 V0)	UL94 V0 Verification of the fire-resistance of plastics (not legally binding)
German Battery Act (2006/66/EC)	German Battery Act (2006/66/EC) Recycling coordinator for Germany GRS-Batterien www.grs-batterien.de
RoHS	Directive 2011/65/EC for the restriction of use of certain hazardous substances in electrical and electronic devices
Waste Electrical and Electronic Equipment (WEEE)	DE 50419 (2006)
Recycling	IEC 61429/A11 (1998)
EN ISO 9001:2015	Quality management
EN ISO 16315:2016	Small craft - Electrical drive systems
ISO 7000:2012	Graphical Symbols for Use on Equipment - Registered symbols, Edition: 4
IEC 60417:2002	Graphical Symbols for Use on Equipment - Registered symbols
IEC 62133 Ed2.0	Secondary cells and batteries containing alkaline or other non-acidic electrolytes - Safety requirements for portable sealed secondary cells, and for batteries made from them, for use in portable applications

Approvals	
DNV-GL	Type approval – maritime

10.5. EMC

This device complies with the EMC protection requirements of Directive 2014/30/EC (Industry), ECE-R10 (Automotive) and IEC 60945:2002 (Maritime) / DNV GL of the European Union (EU) on electromagnetic compatibility. Energy systems from aentron GmbH are developed, tested and classified for their intended electromagnetic environment.

Electromagnetic compatibility (EMC) is the ability of electronic equipment to interact properly in the electronic environment. Even though all energy systems from aentron GmbH are designed and specified to comply with EMC regulatory limits, there is no guarantee that interference will not occur within a system. Energy systems from aentron GmbH are designed to provide reasonable protection against harmful interference when operating with other devices.

aentron GmbH cannot be held liable for non-compliance with the protection requirements resulting from device modifications that are not recommended, including the incorporation of third-party components or equipment. The aentron battery system generates, uses and can radiate radio high frequency energy. Failure to install and use the device in accordance with the instructions of aentron GmbH may result in harmful interference to radio communications. In this case, the user is obliged to remedy the faults at his own expense.

Properly shielded and grounded cables and connectors must be used to comply with emission limit values. aentron GmbH is not responsible for any EMC interference that may result from the use of cables or connectors other than those specified by aentron GmbH, from failure to follow wiring instructions (interactions of power cables with communication cables), or from unauthorized modification or alteration of this device. Unauthorised changes or modifications may void the user's authority to operate the device.

11. Plans

11.1. Maintenance plan

WARNING



Fatal electric shock possible due to improper handling of the lithium-ion battery.



- ▶ When handling and maintaining the lithium-ion battery use suitable test devices and personal safety clothing, safety gloves and protective eyewear.

For the preparation of the maintenance, do the following:

1. Remove the charger from the lithium-ion battery.
2. Switch off the lithium-ion battery.
3. Activate the emergency release on the switch board.
Ensure that the E-Switch and Charger-IN line are isolated.
4. Protect the lithium-ion battery against an accidental switch-on.
Install an appropriate service report at the E-switch board and the charger connector.
5. Measure the DC-output with a calibrated multi-meter.

- ✓ The preparation for the maintenance is done.

11.2. Maintenance Protocol

Name: _____

Date: _____

Components

System-ID _____
 Configuration (XSYP) _____
 Nominal voltage (V) _____
 System voltage (V) _____
 SoC (%) _____
 SoH (%) _____
 Charged (Ah) _____
 Temperature (°C) _____
 Humidity (%) _____

Test-cycle

Weekly
 Monthly
 3. Month
 6. Month
 12. Month

Nr.	Task	Test succesful Yes / No	Necessary measures Test result value	Comments corrective- actions
1.0	Visual check of the battery system			
1.1	Remove all the dirt from the power interfaces			
1.2	Visual check for corrosion-on the battery surfaces and interfaces.			
1.3	Visual check for mechanical damage or deformation of the battery surface and interface.			
1.4 SR	Visual check of power cables (PWR) (BAT), connectors, wiring and inolation.			
1.5	Visual check of the communication cables (Comm), connectors and the inolation.			
1.6 SR	Check of all interfaces and retighten if looseness detected.			
1.7 SR	Check the mounting of the housing at the installation location.			

Nr.	Task	Test successful Yes / No	Necessary measures Test result value	Comments corrective-actions
1.8 SR	Check for the correct connection of the power connectors (RADLOK / SURLOK).			
2.0	Electrical check (just R-Type)			
2.1 SR	<u>Voltage check:</u> 1. The battery is switched off for at least 12 hours. 2. Connect all the power connectors (RADLOK / SURLOK) again. 3. Switch on the battery with the E-Switch. 4. Measure the DC-output of all the modules of the system. 5. If the DC-output of one module differs more than 4 V DC from the normal module value, contact aentron for further support.			
2.2 SR	<u>Temperature check:</u> 1. The battery is switched off for at least 12 hours. 2. The diagnostic interface / display provided by aentron is necessary. 3. Use a calibrated multi-meter with a thermal sensor. 4. Switch on the battery with the E-Switch. 5. Measure the environment temperature of the battery with the multi-meter. 6. Ensure that the difference of the multi-meter measurement compared to the aentron-diagnosis-display is less than ± 5 °C. 7. If the difference of the temperature measurement is more than ± 5 °C, contact aentron for further support.			

Nr.	Task	Test successful Yes / No	Necessary measures Test result value	Comments corrective-actions
2.3 SR	<u>Current:</u> 1. The diagnostic interface / display provided by aentron is necessary. 2. Use a calibrated ohm clamp-meter. 3. Switch on the battery with the E-Switch. 4. Place the ohm clamp-meter on the (-) pole of the DC-output line. 5. Measure the constant ampere for 30 seconds. 6. Check if the difference of the ohm clamp-meter towards the aentron-diagnosis-display is less than ± 2 A. 7. If the latest measurement-difference is larger than ± 2 A, contact aentron for further support.			
3.0	Battery status (only R-Type)			
3.1	<u>SoH</u> - If the SoH < 60 % - contact aentron for further support.			
3.2	<u>SoC</u> - If the SoC differs more than >10 % from the relative voltage scale, contact aentron for further support.			
3.3	<u>Error list</u> - The diagnosis interface / display provided by aentron is necessary. - If you detect any errors, contact aentron for further support.			
4.0	Checking of the safety functions* (Only Type R) <i>* The following checks can only be executed by aentron service personnel or after participating in a certified partner training held by aentron. Eventually the test values may need to be adjusted in order to check the functions.</i>			
4.1 SR	<u>Overvoltage protection:</u> - Checking of the overvoltage „safety limit“ by charging the battery system over the suggested overvoltage-limit (Eventually adjust the safety limit in order to check the functions) - <u>Expected result:</u> Automatic permanent opening of the contactor. An alarm needs to be registered on the display.			

Nr.	Task	Test successful Yes / No	Necessary measures Test result value	Comments corrective-actions
	<ul style="list-style-type: none"> - Information: Reset the safety values after a successful battery check. 			
<p>4.2 SR</p>	<p><u>Undervoltage protection:</u></p> <ul style="list-style-type: none"> - Check of the undervoltage "safety limit", by discharging the battery system under the suggested undervoltage-limit (Eventually adjust the safety limit in order to check the functions) - <u>Expected result:</u> Automatic permanent opening of the contactor. An alarm needs to be registered on the display. - <u>Information:</u> Reset the safety values after a successful battery check. 			
<p>4.3 SR</p>	<p><u>Overtemperature protection:</u></p> <ul style="list-style-type: none"> - Check of the overtemperature „safety limit“ by charging the battery system over the suggested overtemperature-limit (Eventually adjust the safety limit in order to check the functions) - <u>Expected result:</u> Automatic permanent opening of the contactor. An alarm needs to be registered on the display. - <u>Information:</u> Reset the safety values after a successful battery check. 			
<p>4.4 SR</p>	<p><u>Under-temperature protection:</u></p> <ul style="list-style-type: none"> - Check of the under-temperature „safety limit“ by letting the battery system fall under the suggested under-temperature-limit (Eventually adjust the safety limit in order to check the functions) - <u>Expected result:</u> Automatic permanent opening of the contactor. An alarm needs to be registered on the display. 			

Nr.	Task	Test successful Yes / No	Necessary measures Test result value	Comments corrective-actions
	<ul style="list-style-type: none"> - <u>Information:</u> Reset the safety values after a successful battery check. 			
<p>4.5 SR</p>	<p><u>Over-current protection:</u></p> <ul style="list-style-type: none"> - Check of the overcurrent „safety-limit“ by discharging the battery system over the suggested current-limit (Eventually adjust the safety limit in order to check the functions) - <u>Expected result:</u> Automatic permanent opening of the contactor. An alarm needs to be registered on the display. - <u>Information:</u> Reset the safety values after a successful battery check. 			

Date

Location

Sign



aentron GmbH
Dornierstraße 21
82205 Gilching
GERMANY

Phone.: +49 8105 398 98-0
Fax: +49 8105 398 98-29
Email: info@aentron.com

**Modifications and errors reserved
03.2021**